



US006216631B1

(12) **United States Patent**
Wissner-Gross

(10) **Patent No.:** **US 6,216,631 B1**
(45) **Date of Patent:** **Apr. 17, 2001**

- (54) **ROBOTIC MANIPULATION SYSTEM UTILIZING PATTERNED GRANULAR MOTION**
- (75) Inventor: **Alexander D. Wissner-Gross**, New Hyde Park, NY (US)
- (73) Assignee: **The Mitre Corporation**, McLean, VA (US)
- (*) Notice: Subject to any disclaimer, the term of this patent is extended or adjusted under 35 U.S.C. 154(b) by 0 days.
- (21) Appl. No.: **09/372,619**
- (22) Filed: **Aug. 12, 1999**
- (51) **Int. Cl.⁷** **C23C 14/02**
- (52) **U.S. Cl.** **118/50.1**; 118/620; 118/621; 118/623; 118/625; 118/640; 204/222; 204/298.29
- (58) **Field of Search** 118/612, 712, 118/50.1, 620, 621, 623, 624, 625, 640, DIG. 5; 427/459, 473, 474, 475, 553, 213, 903; 361/225, 226, 230, 233; 399/258; 347/158; 423/445 B; 204/222, 298.29

- (56) **References Cited**
- U.S. PATENT DOCUMENTS**
- 4,685,419 * 8/1987 Nakajima 118/620
- 4,794,878 * 1/1989 Connors et al. 118/612
- 5,591,312 * 1/1997 Smalley 204/157.41
- 5,620,512 * 4/1997 Gruen et al. 423/445 B
- 5,876,684 * 3/1999 Withers et al. 423/445 B

OTHER PUBLICATIONS

Das, Pranab K., et al., "Phase Boundaries in Vertically Vibrated Granular Materials," *Physics Letters A*, vol. 242, No. 6, 326-328 (Jun. 8, 1998).

Shvartsburg, Alexandre A., et al., "Mobilities of Carbon Cluster Ions: Critical Importance of the Molecular Attractive Potential," *Journal of Chemical Physics*, vol. 108, No. 6 (Feb. 8, 1998).

Falvo, M.R., et al., "Bending and Buckling of Carbon Nanotubes Under Large Strain," *Nature*, vol. 389, 582-584 (Oct. 9, 1997).

Falvo, M.R., et al., "Nanometre-Scale Rolling and Sliding of Carbon Nanotubes," *Nature*, vol. 397, 236-238 (Jan. 21, 1999).

Guo, Ting, et al., "Self-Assembly of Tubular Fullerenes," *Journal of Physical Chemistry*, vol. 99, No. 26, 10694-10697 (1995).

Hertel, Tobias, et al., "Manipulation of Individual Carbon Nanotubes and Their Interaction with Surfaces," *Journal of Physical Chemistry B*, vol. 102, Issue 6, 910 (1998).

Lee, Young Hee, et al., "Catalytic Growth of Single-Wall Carbon Nanotubes: An Ab Initio Study," *Physical Review Letters*, vol. 78, No. 12, 2393-2396 (Mar. 24, 1997).

Lent, C.S., et al., "Quantum Cellular Automata," *Nanotechnology*, vol. 4, 49 (1993).

Melo, Francisco, et al., "Hexagons, Kinks, and Disorder in Oscillated Granular Layers," *Physical Review Letters*, vol. 75, No. 21, 3838-3841 (Nov. 20, 1995).

(List continued on next page.)

Primary Examiner—Laura Edwards
(74) *Attorney, Agent, or Firm*—Rosenberg, Klein & Lee
(57) **ABSTRACT**

A system (100, 100', 100'') and method for robotic manipulation of objects (130) is provided wherein particulates (110, 110') are agitated by the transfer of energy thereto to establish patterned granular motion of the particulates (110, 110'). The patterned granular motion of the particulates (110, 110') forms standing waves (112). The objects (130) align themselves with the standing waves (112) and thus are dynamically arranged in a configuration established by the location of the standing waves (112). The location of the standing waves (112) can be predetermined by controlling the waveform of the signals applied to the energy application system (140). The predetermined waveforms are supplied from the signal source (150, 154) to the energy application system (140).

28 Claims, 14 Drawing Sheets

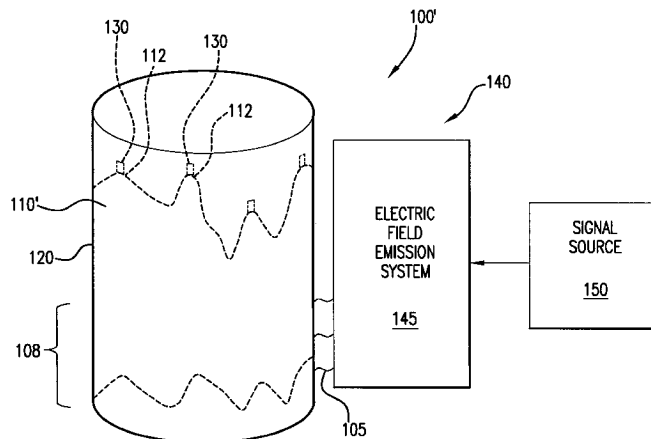

OTHER PUBLICATIONS

- Feynman, Richard, "There's Plenty of Room at the Bottom: An Invitation to Enter a New Field of Physics," *Engineering and Science*, California Institute of Technology (Feb. 1960).
- Gamaly, Eugene, G., et al., "On the Mechanism of Carbon Nanotube Formation in the Arc Discharge," in *Physics and Chemistry of Fullerenes and Derivatives: Proceedings of the International Winterschool on Electronic Properties of Novel Materials*, H. Kuzmany et al., ed., World Scientific Publishing Co., 546–550 (1995).
- Melo, Francisco, et al., "Transition to Parametric Wave Patterns in a Vertically Oscillated Granular Layer," *Physical Review Letters*, vol. 72, No. 1, 172–175 (Jan. 3, 1994).
- Montemerlo, M.S., et al., "Technologies and Designs for Electronic Nanocomputers," MITRE Report No. MTR 96W0000044 (1996).
- Ren, Z.F., "Synthesis of Large Arrays of Well-Aligned Carbon Nanotubes on Glass," *Science*, vol. 282, 1105–1107 (Nov. 6, 1998).
- Shinbrot, Troy, "Competition Between Randomizing Impacts and Inelastic Collisions in Granular Pattern Formations," *Nature*, vol. 389, 574–576 (Oct. 9, 1997).
- Smalley, Richard E., et al., "Self-Assembly of Fullerene Tubes and Balls."
- Tans, W., et al., "Individual Single-Wall Carbon Nanotubes as Quantum Wires," *Nature*, vol. 386, 474–477 (Apr. 3, 1997).
- Thess, A., et al., "Crystalline Ropes of Metallic Carbon Nanotubes," *Science*, vol. 273, 484–487 (Jul. 26, 1996).
- Umbanhowar, Paul B., "Localized Excitations in a Vertically Vibrated Granular Layer," *Nature*, vol. 382, 793–796 (Aug. 29, 1996).
- Umbanhowar, Paul B., "Patterns in the Sand," *Nature*, vol. 389, 541–542 (Oct. 9, 1997).
- Whetten, Robert L., et al., "Fullerenes Under Extreme Temperatures and Stress: Collisions of Fullerenes with Surfaces and with Other Fullerenes," *Proceedings of the Adriatico Research Conference: Clusters and Fullerenes*, New Jersey, World Scientific Publishing Co. (Conference date: Jun. 23–26, 1992).
- Wassgren, C.R., et al., "Vertical Vibration of a Deep Bed of Granular Material in a Container," *Journal of Applied Mechanics*, vol. 63, No. 3, 712–719 (Sep. 1996).
- Yakobson, B.I., et al., "Nanomechanics of Carbon Tubes: Instabilities Beyond Linear Response," *Physical Review Letters*, vol. 76, No. 14, 2511–2514 (Apr. 1, 1996).
- Zhong, W., et al., "Total Energy Calculations for Extremely Large Clusters: The Recursive Approach," *Solid State Communications* 86, 607–612 (1993).

* cited by examiner

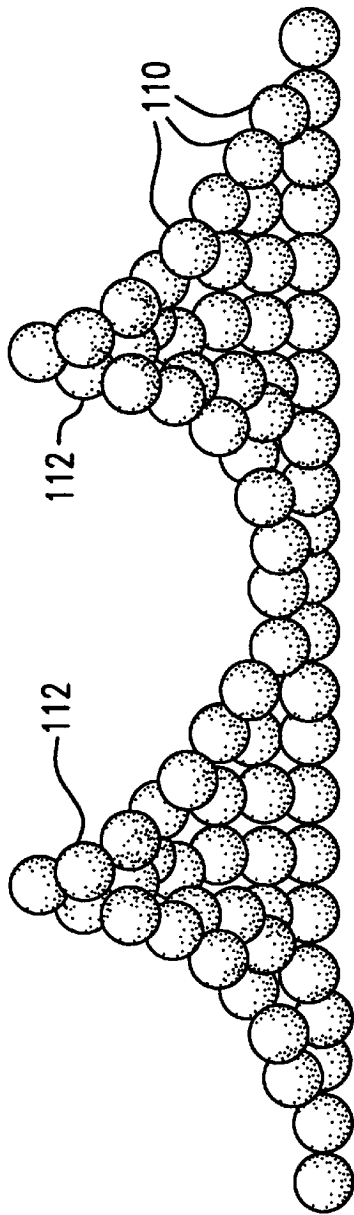

FIG. 1

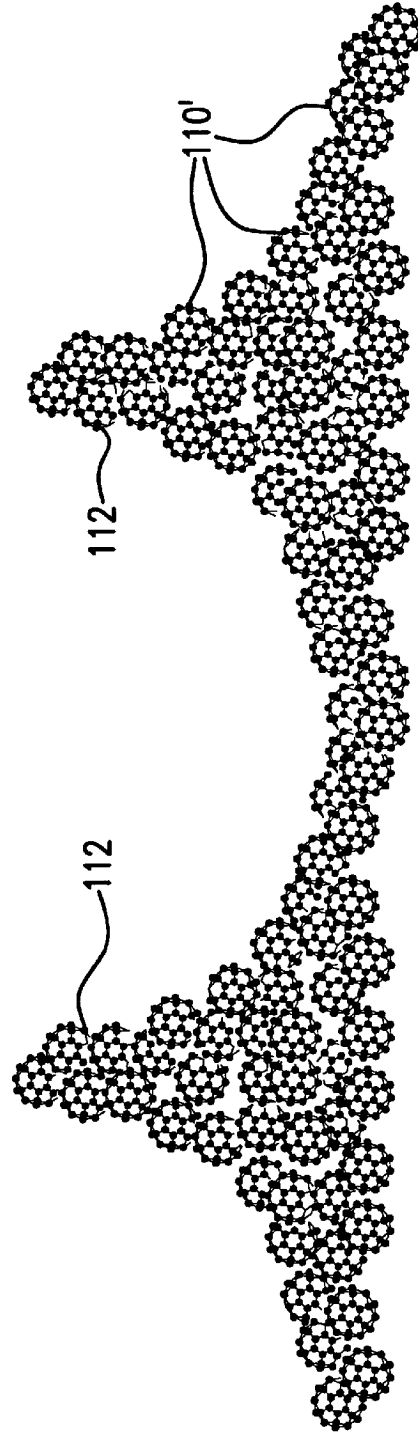

FIG. 2

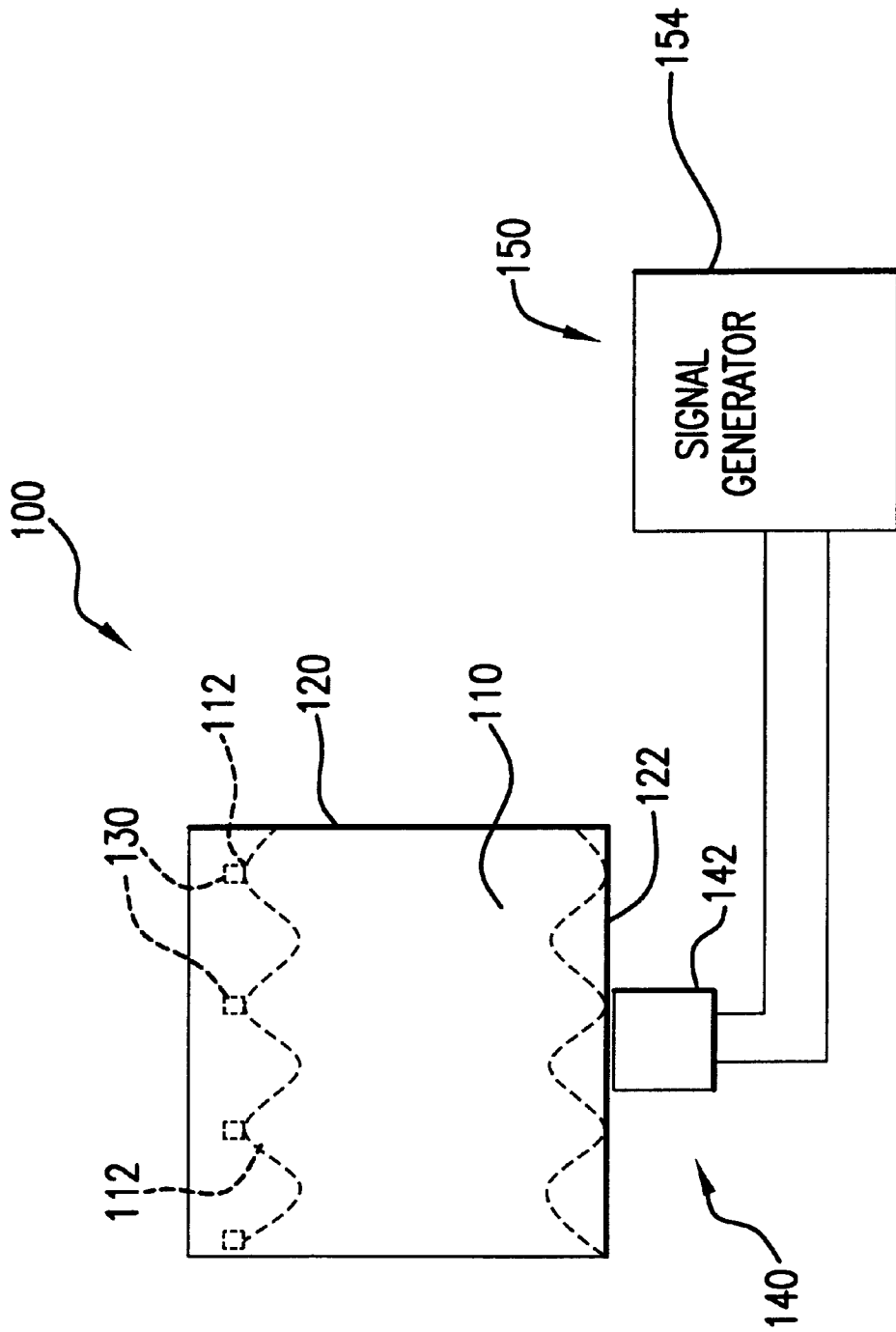

FIG. 3

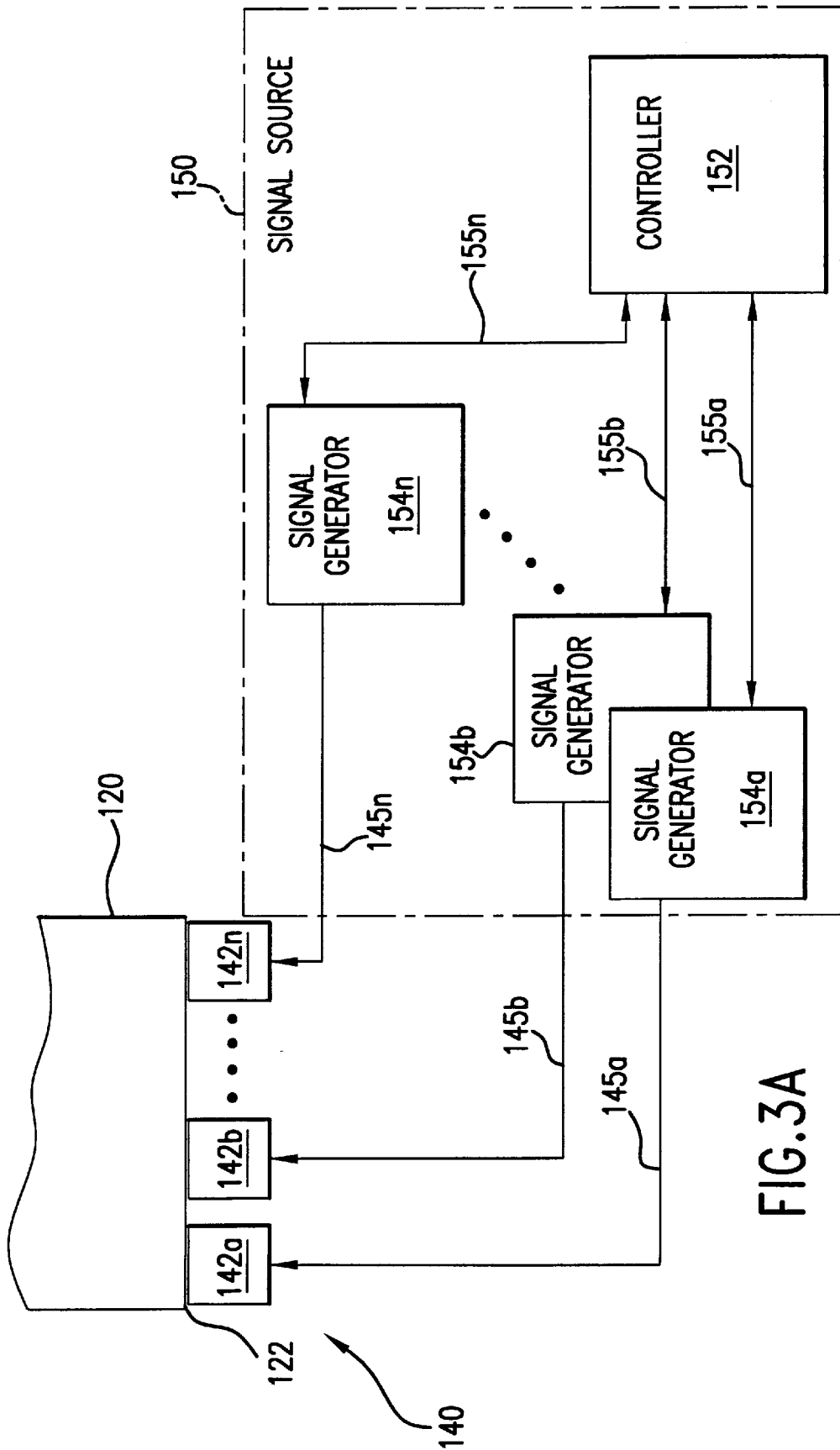

FIG. 3A

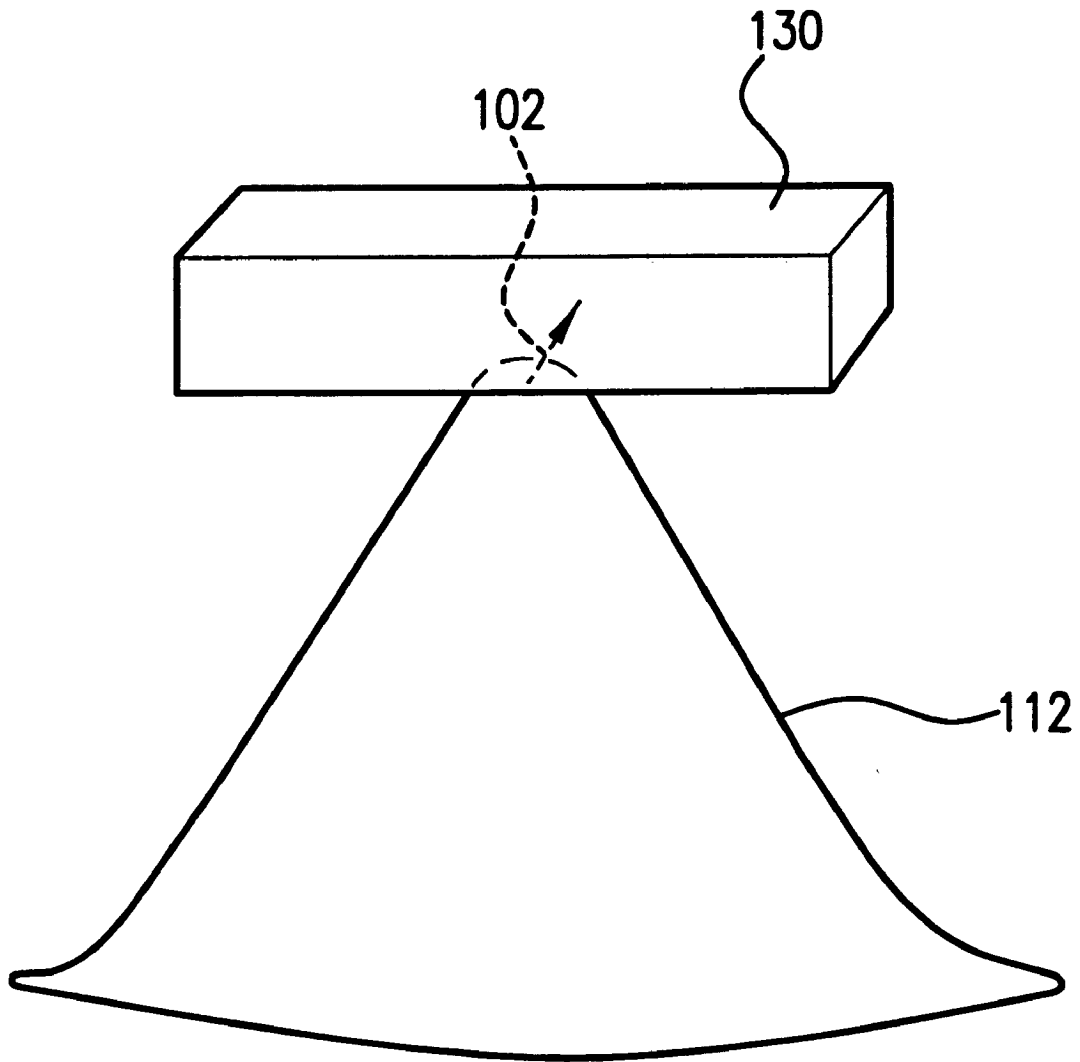

FIG. 4

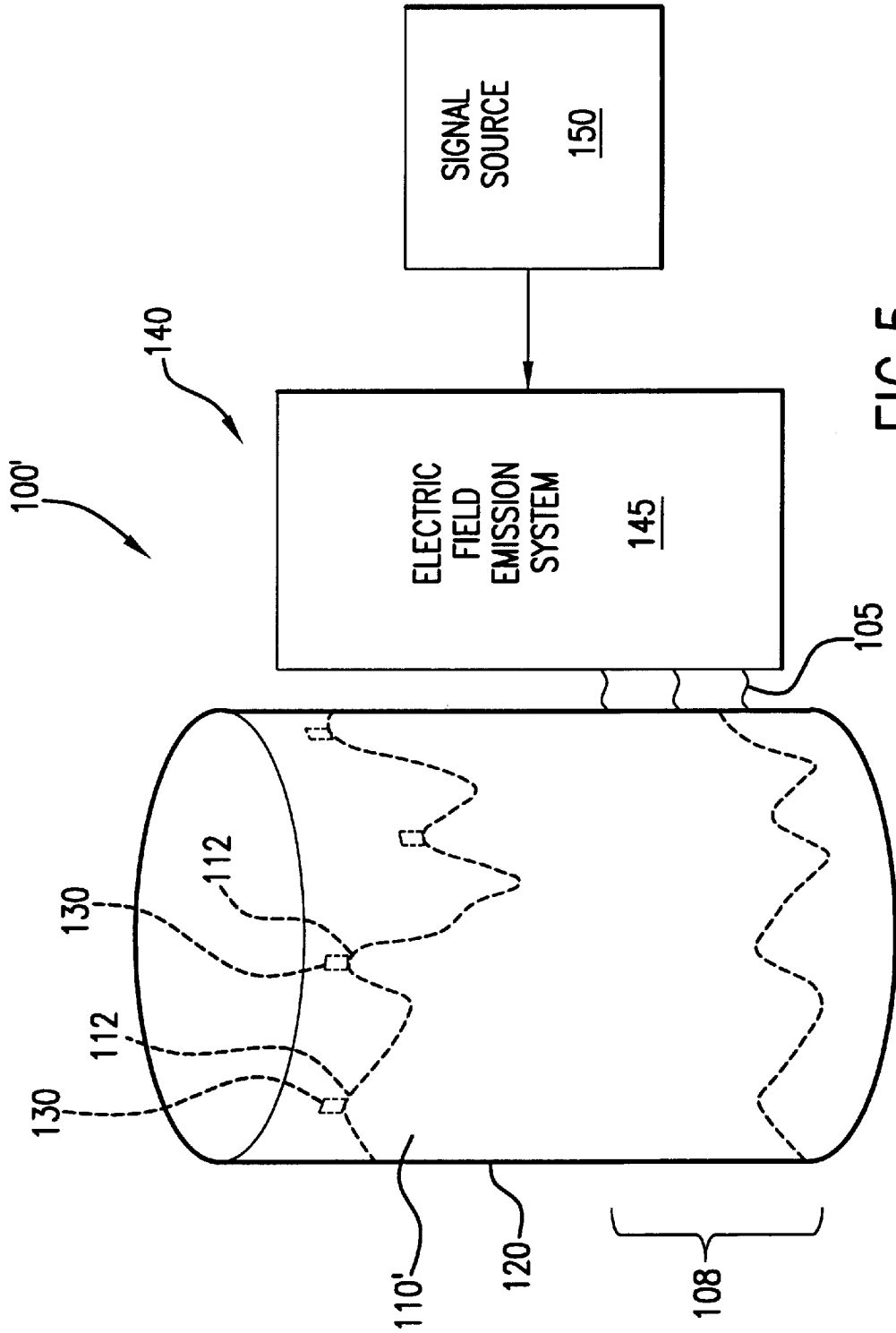

FIG. 5

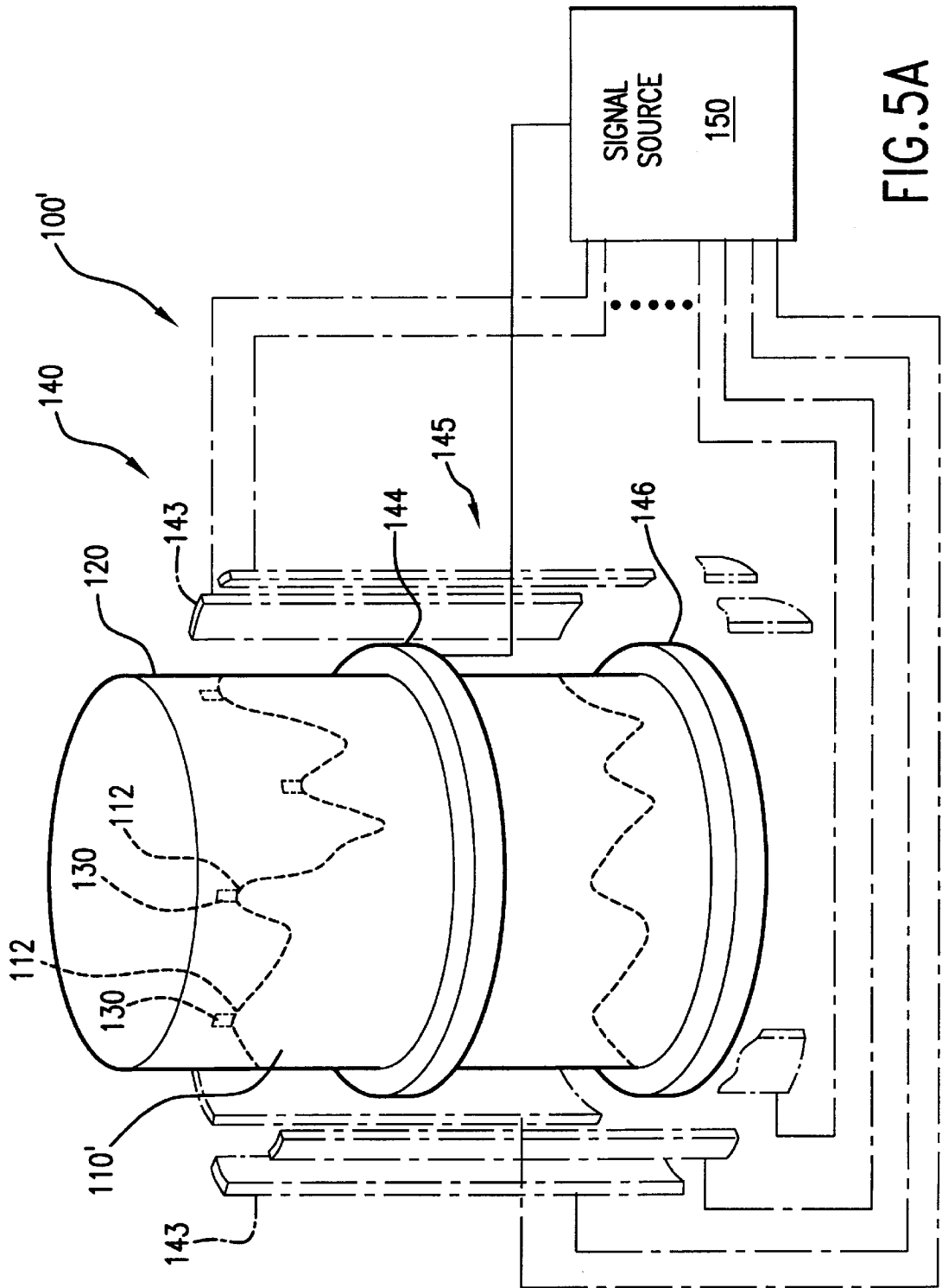

FIG.5A

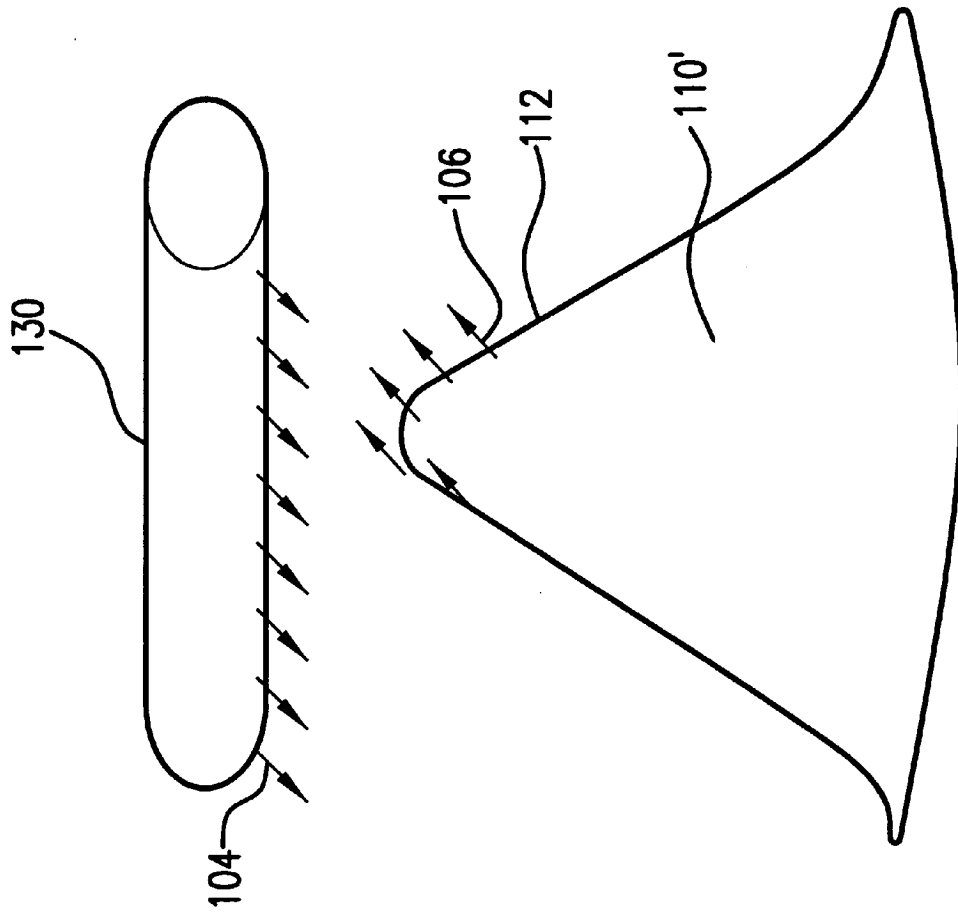
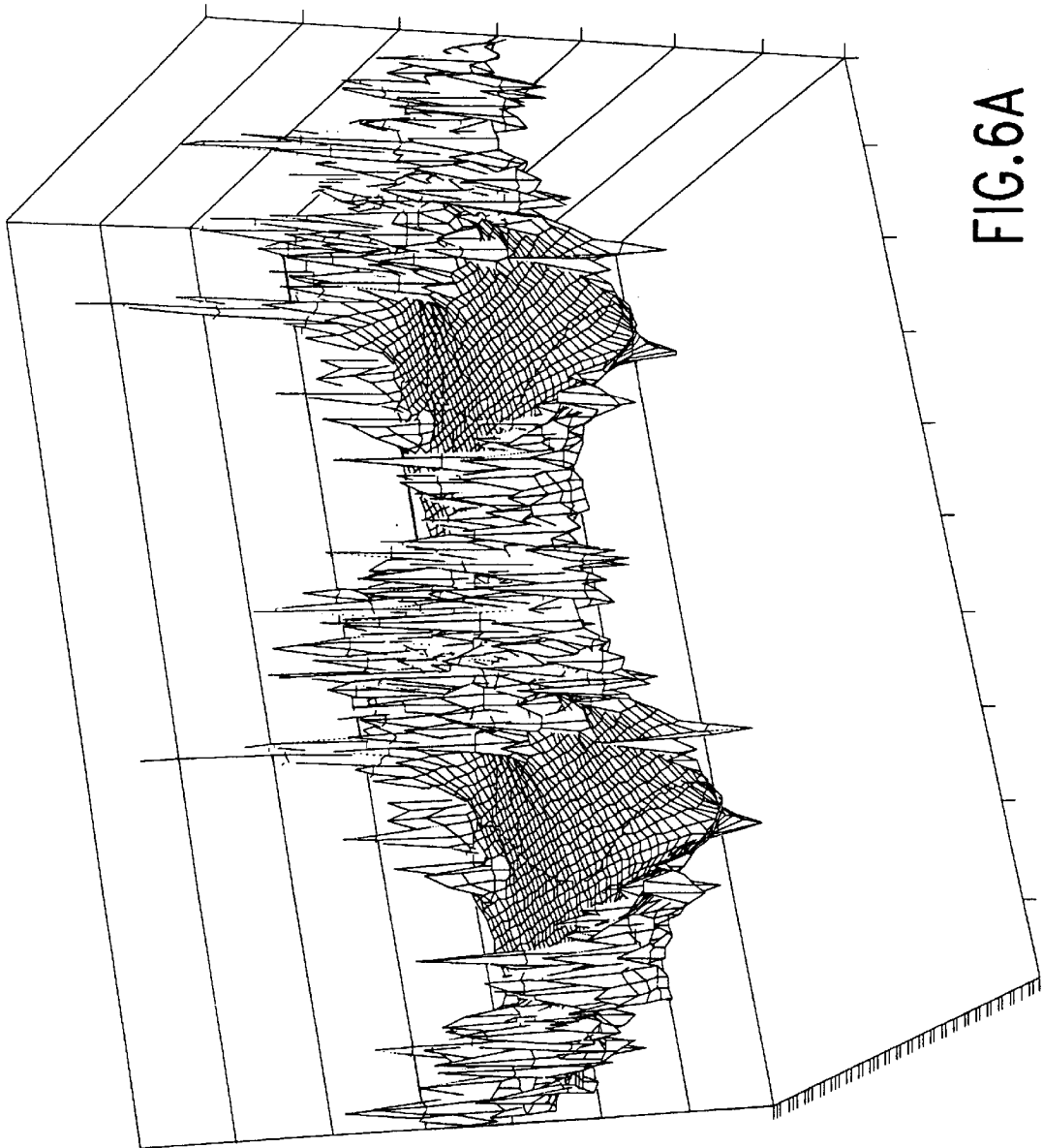

FIG.6



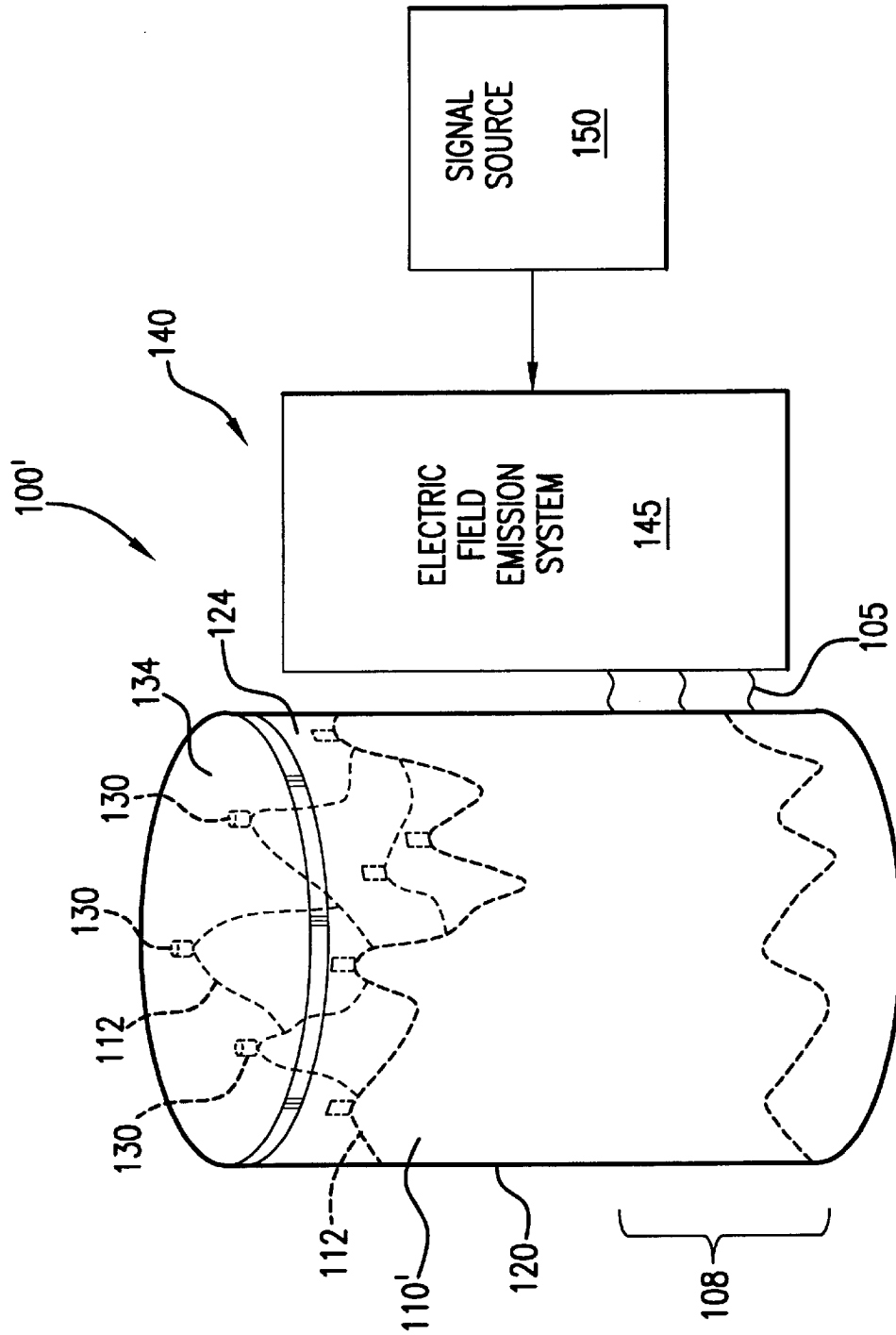

FIG.7

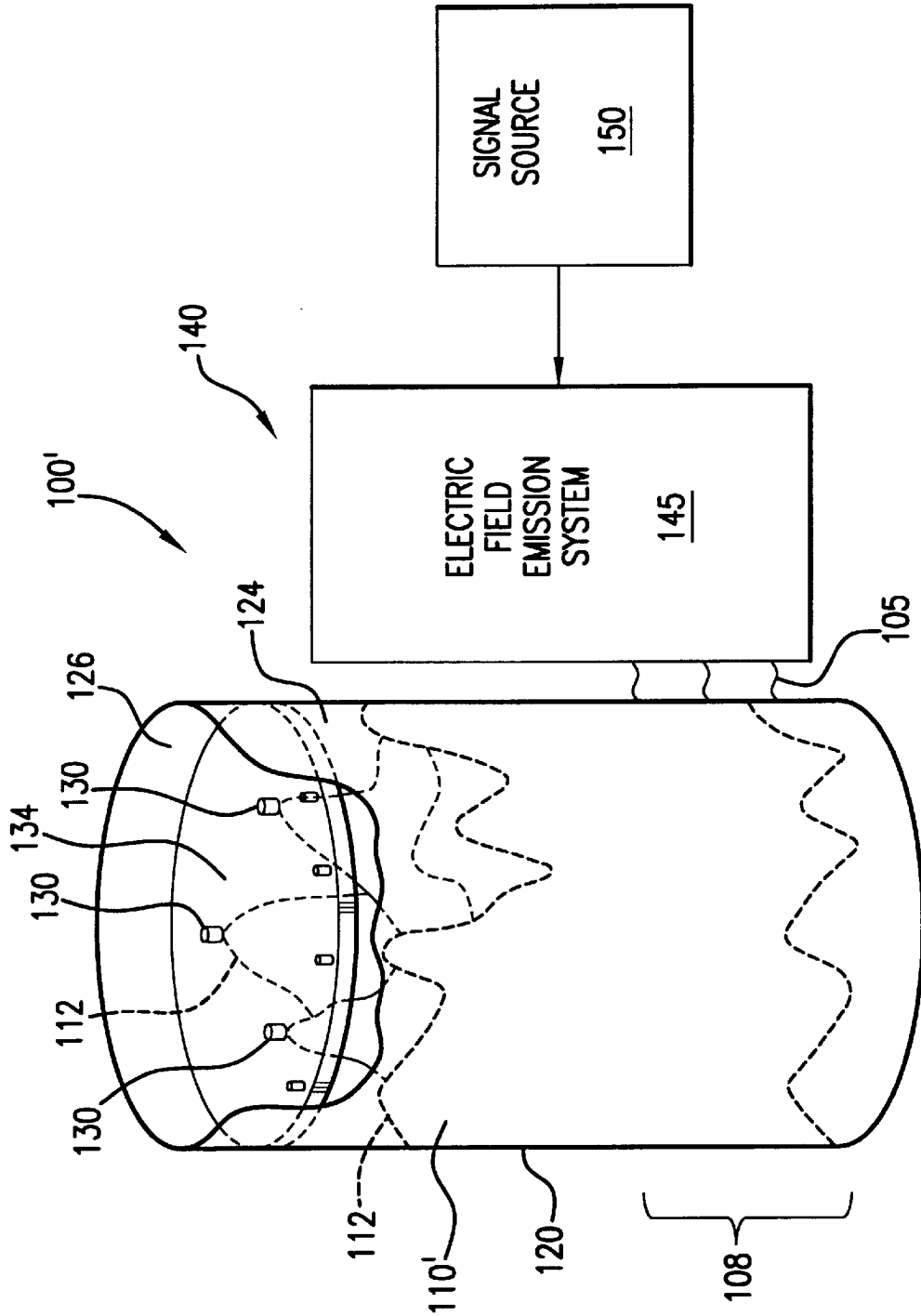

FIG.8

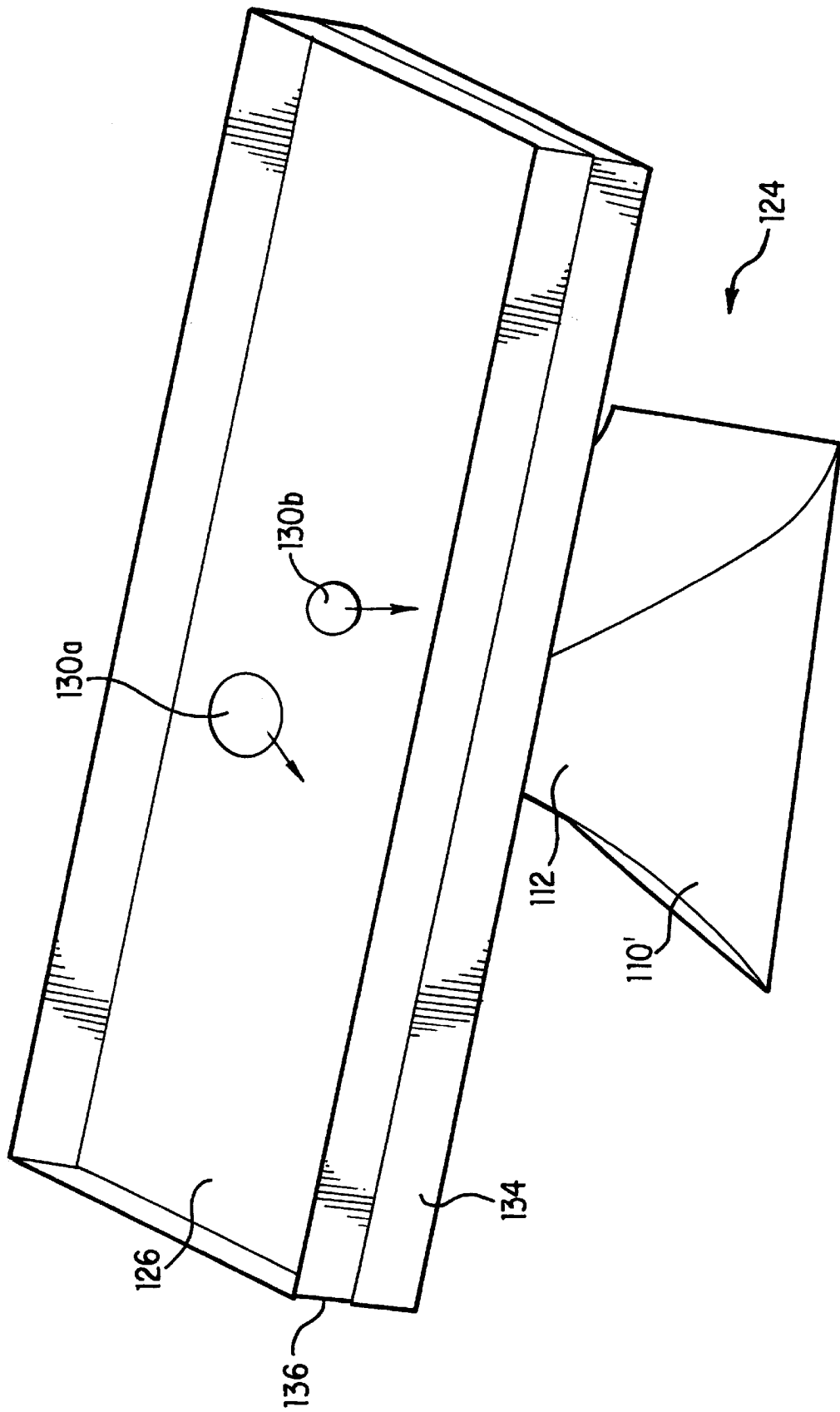

FIG. 9

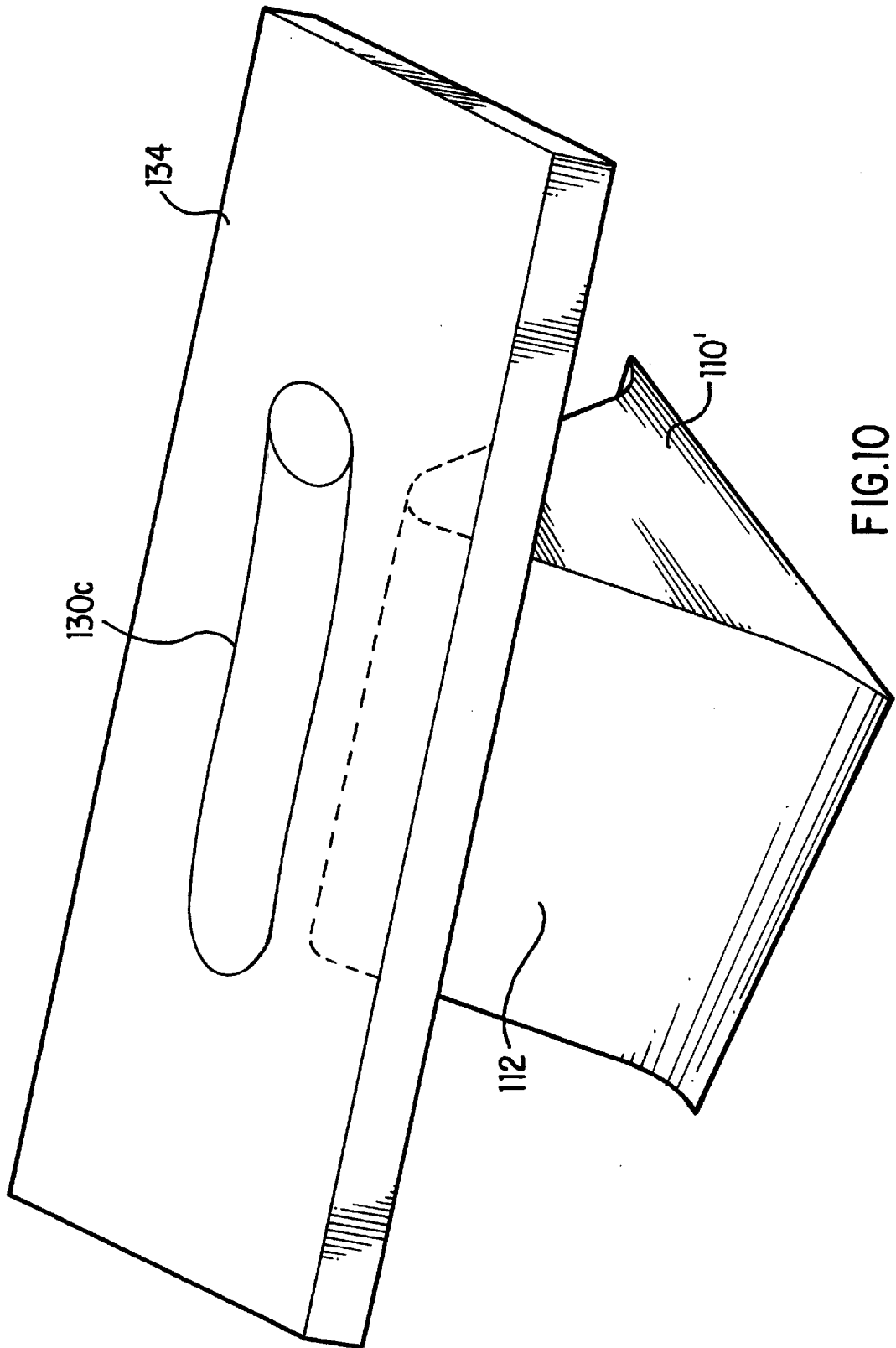

FIG. 10

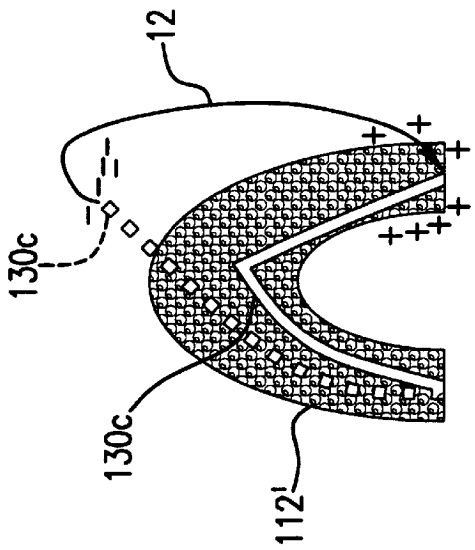

FIG. 11A

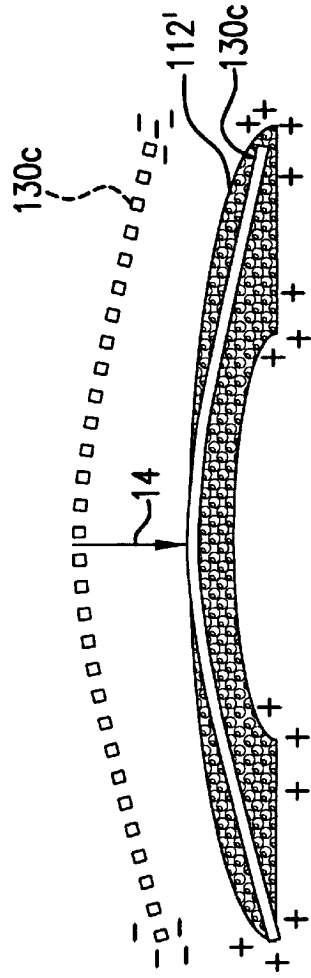

FIG. 11B

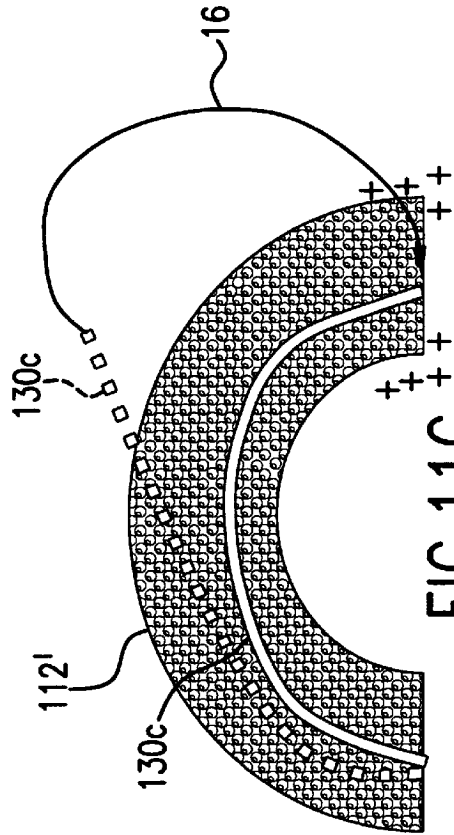

FIG. 11C

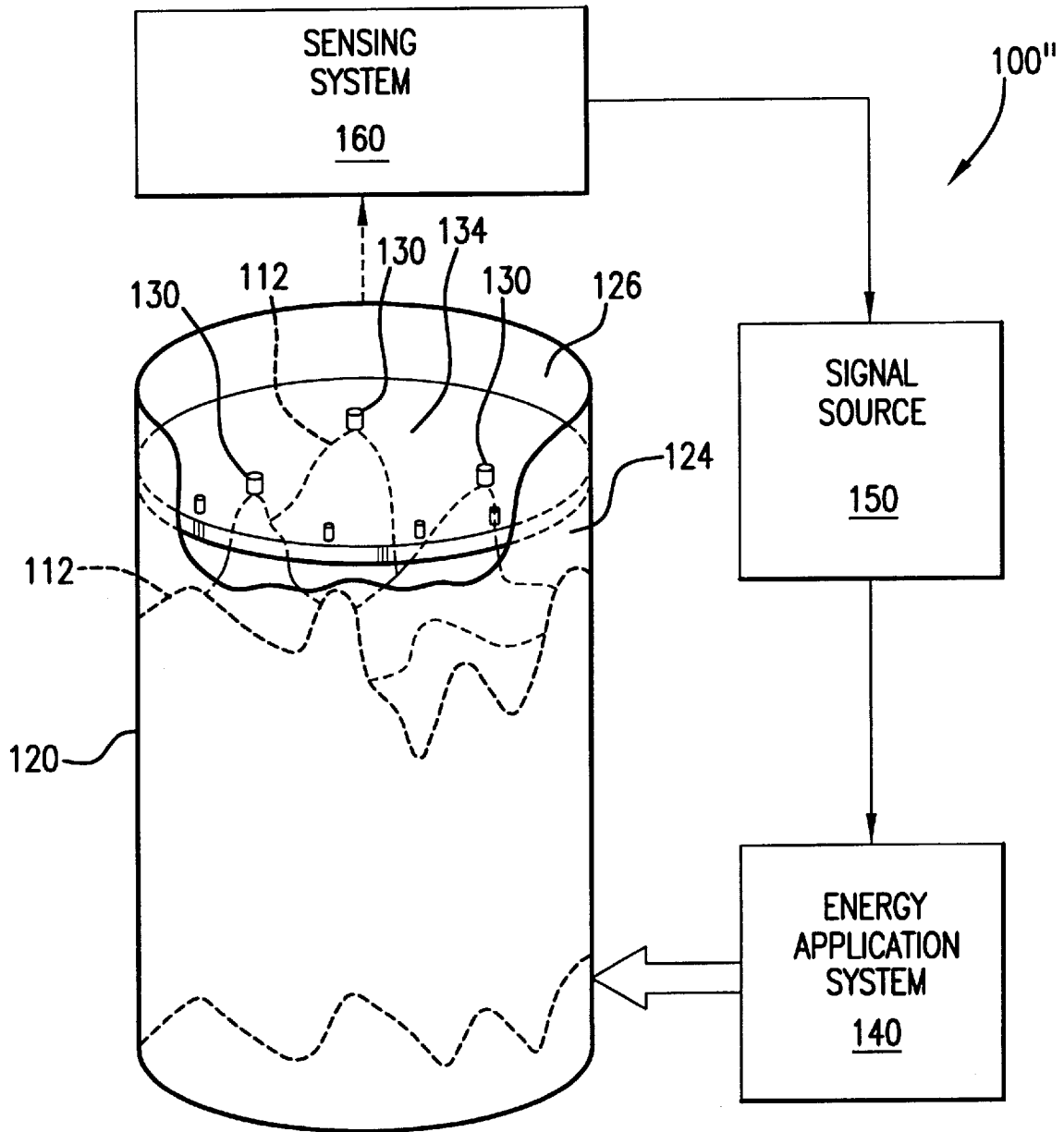

FIG.12

ROBOTIC MANIPULATION SYSTEM UTILIZING PATTERNED GRANULAR MOTION

BACKGROUND OF THE INVENTION

1. Field of the Invention

This invention directs itself to the use of patterned granular motion for robotic manipulation of a plurality of objects. In particular, this invention directs itself to the use of patterned granular motion phenomena, wherein a plurality of standing waves of particulates are positioned by controlling the waveform of energy transferred to the particulates. More in particular, this invention pertains to the use of patterned granular motion where molecules are used as the particulates, wherein the molecules are agitated by the interaction between charges on the molecules and an electric field applied thereto. Still further, this invention directs itself to the formation of nanometer-scale assemblies or systems, wherein nanometer-sized components are dynamically arranged by the electric fields which are formed by the standing waves of particulates that are established when patterned granular motion is induced by the transfer of energy to those particulates.

2. Prior Art

The evolution of solid-state electronics from discrete devices to packaged circuits and systems of ever-increasing complexity has been successful, in part, due to the ability to produce the complex combinations of circuit elements en masse. The ability to produce multiple identical circuits simultaneously provides an efficiency that makes the costs of the circuits attractive for industrial and commercial use. The evolution of such circuits utilizing ever smaller components and circuit patterns is pressing mass production methods for such solid-state devices to their limits.

Now that nanoscale electronic components and circuits, formed by single molecules, have been realized, mass production techniques for the assembly of nanoscale circuits and systems are needed. Currently, mechanosynthesis utilizing a scanning tunneling microscope or an atomic force microscope is used to manipulate molecular wires and devices, serially producing one nanoscale circuit at a time. While chemosynthesis promises to produce a multiplicity of molecular circuits simultaneously, methods for segregating each circuit produced have not evolved as yet. Thus, there is no practical method available to produce multiple nanoscale integrated-like circuit structures simultaneously. Likewise, there are no practical methods available to assemble multiple nanoscale mechanical assemblies or quantum systems simultaneously.

Patterned granular motion is a recently discovered, distinctive mechanical behavior, observed in thin layers of granular media undergoing periodic vertical oscillation. This phenomenon is characterized by the formation of standing waves of the granular media. These standing waves are generated by the application of vertical oscillation in the thin granular layers. Unique patterns of standing waves can be formed, with such patterns as square, striped, oscillon, and hexagonal thus far having been identified.

The granules are typically formed by glass or metallic spheres having a diameter ranging from 0.05–3 mm. To date, the interest in patterned granular motion has been substantially academic, without significant industrial application.

SUMMARY OF THE INVENTION

It is therefore an object of the present invention to provide a system and method for bulk-effect robotic manipulation

utilizing the phenomenon of patterned granular motion. The system for robotic manipulation of a plurality of objects includes a container for receiving the objects therein. A plurality of particulates are disposed in the container and an assembly for applying energy to the plurality of particulates is provided to establish patterned granular motion thereof and thereby form a plurality of repeating vertically directed standing waves. A signal generator is provided that is coupled to the energy application assembly for supplying the energy with predetermined waveforms to dynamically position the standing waves at predetermined positions one with respect to another. The predetermined positions of the standing waves dynamically arrange the objects in a predetermined configuration. From another aspect, a method for robotic manipulation of a plurality of objects is provided wherein a container is provided and a plurality of particulates are provided in the container. A plurality of objects to be manipulated are added to the container and the plurality of particulates are agitated with energy having predetermined waveforms to generate standing wave patterns therewith. The standing wave patterns of particulates dynamically arrange the objects. A substrate is positioned in the container, with the substrate being adapted for adhesion of the objects thereto.

BRIEF DESCRIPTION OF THE DRAWINGS

FIG. 1 is a schematic illustration of patterned granular motion in particulates of micron or millimeter size;

FIG. 2 is a schematic illustration of patterned granular motion utilizing C_{60} molecules as particulates;

FIG. 3 is a schematic block diagram illustrating one embodiment of the present invention;

FIG. 3A is a schematic block diagram illustrating an alternative configuration for the energy application system used in the invention of the subject Patent Application;

FIG. 4 is a schematic illustration of an object being manipulated by the invention of the subject Patent Application;

FIG. 5 is a schematic representation of an alternate embodiment of the invention of the subject Patent Application;

FIG. 5A is a schematic illustration of the embodiment of FIG. 5 showing exemplary electric field emission electrode arrangements of the present invention;

FIG. 6 is a schematic illustration of an object being manipulated by the alternate embodiment of the present invention;

FIG. 6A is a three-dimensional plot illustrating Coulombic field intensities derived from a computer simulation of the present invention;

FIG. 7 is a schematic block diagram of the alternate embodiment of the present invention with a substrate incorporated at a first location;

FIG. 8 is a schematic block diagram of the alternate embodiment of the present invention with a substrate incorporated at a second location;

FIG. 9 is a schematic illustration of the present invention wherein the objects being manipulated are disposed in a gel;

FIG. 10 is a schematic illustration of the present invention wherein the object being manipulated is a carbon nanotube;

FIGS. 11A, 11B and 11C are schematic illustrations of a carbon nanotube being deformed in various ways by the present invention; and,

FIG. 12 is a schematic illustration of the present invention incorporating feedback.

DESCRIPTION OF THE PREFERRED EMBODIMENTS

Referring to FIGS. 1–11, there is shown, robotic manipulation system **100**, **100'** for dynamically manipulating objects utilizing patterned granular motion. As will be seen in following paragraphs, robotic manipulation system **100**, **100'** is specifically directed to the concept of bulk manipulation of objects to fabricate a multiplicity of structures in parallel. Robotic manipulation system **100'** is particularly directed to application of nanometer scale assemblies or systems, such as the dynamic arrangement of molecules to provide a circuit pattern, position a molecular electronic device, form a mechanical structure or sort molecules by positioning one type relative to another.

Referring particularly to FIGS. 1 and 3, system **100** is shown wherein a plurality of particulates **110** are disposed within the container **120**. The energy application system **140** applies energy to the container **120** to vibrate at least one wall thereof, such as the bottom wall **122**. The vibrations of wall **122** establish patterned granular motion in the particulates **110** to form a plurality of repeating vertically directed standing waves **112**. Multiple walls can be vibrated in order to achieve a particular pattern of standing waves **112**. Within container **120** there is also provided a plurality of objects **130** which are to be manipulated. Collisions between the particulates **110** of the standing waves **112** with the objects **130** dynamically arrange the objects in correspondence with the standing waves. Where the standing waves are formed as “stripes”, rows of objects can be realized. By forming standing wave patterns utilizing energy applied with complex waveforms, standing waves can be located at predetermined positions.

The energy application system **140** may include one or more vibratory actuators **142** which are driven by a signal source **150**. A vibratory actuator **142** may be an electromechanical or piezoelectric device, for example, that is mechanically coupled to the container wall **122**. Alternately, piezoelectric devices may be incorporated into the structure of the bottom wall in the form of an integral structure. The signal source **150** includes at least one signal generator **154** having the capability of output of electrical signals having predetermined waveforms for driving a vibratory actuator **142**. The signals output from signal generator **154** may be non-sinusoidal oscillatory signals to form non-uniformly spaced standing waves of the particulate media **110**.

As shown in FIG. 3A, the energy application system **140** may be formed by a plurality of vibratory actuators **142a–142n**, each respectively driven by the signal source **150**. Signal source **150** may be formed by a single signal generator having multiple outputs or, as shown, is formed by a plurality of signal generators **154a–154n**, each having an output **145a–145n** respectively coupled to the vibratory actuators **142a–142n**. In order to coordinate the resultant vibratory patterns formed by the media within container **120**, the signal generators **154a–154n** are coupled into a controller **152** which provides command signals to each of the signal generators **154a–154n** and may receive status therefrom. Controller **152** may be a microprocessor or personal computer programmed to control the signal generators. The plurality of vibratory actuators **142a–142n** may be discrete devices or integrally formed in one or more walls of the container.

Referring back to FIG. 3 and additionally to FIG. 4, the energy applied to the particulates **110** within container **120** establishes vertical standing waves **112** which simultaneously mechanically manipulate the plurality of objects

130, by collisions therewith. Multiple collisions occur between the particulates in each of the standing waves with respective objects **130**, applying forces thereto, represented by the directional arrow **102**, to position an object dynamically in correspondence with a standing wave. Thus, where the standing waves establish particular patterns (e.g., stripes, squares, hexagons, etc.), the objects **130** can be arranged, dynamically, in correspondence with those patterns. The patterns can be established, as desired, by controlling the waveform and frequency of the energy applied to the particulates **110**. The objects being manipulated can be integrated circuit chips, discrete circuit components, conductive elements, or mechanical components, for example. The dynamic arrangement of the objects can represent a plurality of substantially identical circuits or patterns formed simultaneously. Similarly, the objects manipulated can be mechanical components that are assembled into a plurality of substantially identical mechanical assemblies or systems. As will be described with respect to the embodiment of FIG. 7, a substrate **134** is positioned in the container **120** and adapted for adherence of the objects **130** thereto.

The granular behavior of particulates through vertical vibration in the container **120** down to micron scale by the addition of energy to micron-scale particulates has been established. However, in order to manipulate nanometer-scale objects, it will be necessary to establish patterned granular motion in nanometer-scale particulates, which heretofore has not been accomplished.

With respect to inducing patterned granular motion among nanometer-scale particulates, there are a number of problems associated with the addition of energy to the collection of nanometer-scale particulates through collision with the container's walls. Imperfections in the oscillating wall of the container can cause anisotropy in lateral rebound velocities of the particulates and the normal force of the oscillating wall will not likely be distributed evenly, on a nanometer scale, over the particulates, causing particulates with low fracture energies to break upon collision. Further, the precision of control of the physical oscillating wall needs to produce standing waves with nanometer-scale spacings, which is not easily accomplished with transducers of current technology.

In order to overcome those problems, a spatially uniform electric field, represented by the lines **105**, is applied to a portion **108** of container **120**, as illustrated in FIG. 5. Utilizing particulates **110'**, which are charged, the oscillating electric field emulates a vertically vibrating surface, vertically accelerating the particulates. Using particulates of such small size introduces other problems which must be overcome. Brownian motion has to be minimal, inter-particle collisions need to properly dissipate energy, and the particulates themselves have to be of sufficient structural strength to survive collisions without fragmentation. The nanometer-scale particulates selected for use, particulates in which patterned granular motion is to be established utilizing oscillatory electric fields, are single molecules having a closed-cage structure. Such a closed-cage structure is found in the C_{60} molecule, which structure is substantially spherical. Other molecules with similar properties, such as C_{80} , C_{140} , C_{180} and C_{240} , also could serve as nanometer-scale particulates. The C_{60} molecules, known as buckminsterfullerene molecules or “buckyballs” can be charged and have sufficient strength to survive the multiplicity of collisions which occur when patterned granular motion is established. As illustrated in FIG. 2, the buckminsterfullerene molecules are used as the particulates **110'** and by the application of one or more oscillating electric fields establish

vertical standing waves **112** corresponding to that which is seen with larger particulates that are mechanically accelerated.

In order to accelerate the particulates **110'** vertically, the particulates **110'** are charged and the energy application system **140** of system **100'** includes an electric field emission system **145** having a plurality of electrodes disposed in proximity of container **120** for establishing one or more oscillating electric fields therein. The particulates **110'** are disposed between at least two electrode plates to which electrical signals having predetermined waveforms are applied from the signal source **150**. That arrangement emulates a vertically vibrating surface to establish patterned granular motion in the particulates. The vertical standing waves **112** of particulates **110'** will dynamically arrange nanometer-scale objects **130**. However, instead of being manipulated by mechanical collisions, the nanometer-scale objects, objects each of whose size, diameter or smallest outside contour dimension, is less than 10 microns, are manipulated by Coulombic fields.

As an example of electrode arrangements for use in establishing the required electric fields within container **120**, reference is now made to FIG. **5A**. The acceleration of charged particulates **110'** is achieved by the electric field formed between the oppositely charged electrode plates **144** and **146** surrounding container **120**. While plates **144** and **146** are depicted as being annular, such is only exemplary and may be formed in a multitude of different contours without departing from the inventive concepts embodied therein.

Referring additionally to FIG. **6**, the oscillating field established between the plates **144** and **146** adds energy to the charged particulates **110'**, the energy addition being oscillatory, but not necessarily periodic. Each of the standing waves that are thus formed establish respective fields **106** that exert appreciable Coulombic forces on respective objects **130**, which objects themselves have fields **104** that interact with a respective field **106**.

The objects to be manipulated **130** may be uncharged, or charged with a polarity either the same or opposite to that of the charge polarity of the granular standing waves **112**, in order to establish a predetermined arrangement of objects or deformation thereof. Where an object **130** has a charge, having a polarity opposite to that of the representative standing wave **112**, an attraction is established therebetween. As will be discussed in following paragraphs, the Coulombic charges established by the pattern of standing waves generated within container **120** can be utilized to deform objects into a predetermined configuration, as opposed to just arranging them in particular patterns, or for utilizing differences in charge to sort the objects.

Referring back to FIG. **5A**, the electrode plates **144** and **146** are electrically coupled to the signal source **150**, the signal source providing oscillatory signals with predetermined waveforms in order to establish a desired standing wave pattern of particulates **110'** within the container **120**. As discussed with respect to FIGS. **3** and **3A**, the signal source **150** may be formed by one or more signal generators which can be programmed, internally or through the use of an external controller, to synthesize the required waveform pattern. The waveform of the signal generated may be expressed as a Fourier series wherein the coefficients are selected to provide an output signal waveform of a desired shape. By controlling the shape of the waveform of the signal applied to the plates **144**, **146**, the locations of the standing waves of particulates can be controlled. Therefore,

the shape or topology of the field generated by the standing waves can also be controlled. By controlling the shape or topology of the field generated by the standing waves of particulates **110'**, the objects **130** can be arranged in a predetermined pattern, or otherwise manipulated in a known way.

The locations of standing waves may be further controlled by a combination of multiple electric fields established within container **120**. In addition to the field established between the electrode plates **144** and **146**, additional fields can be established between respective opposing pairs of side electrodes **143**, that may be added in proximity to container **120**. The plurality of side electrodes **143**, together, substantially surround container **120**, each being separately energized by signals having predetermined waveforms. As another alternative, the plates **144**, **146** can be subdivided into a plurality of sections, each being separately energized. That arrangement can be used alone, or in combination with a plurality of side electrodes **143**, and is analogous to the use of the plurality of vibratory actuators of the embodiment of FIG. **3A**.

As an illustration of the degree of control that is achievable, reference is now made to the three-dimensional plot shown in FIG. **6A**. The plot illustrates a distribution of field intensities obtained by a computer simulation. The simulation shows that the Coulombic fields can be distributed in a predetermined pattern, corresponding to the distribution of standing waves of particulates, wherein the distribution of standing waves is controlled by the electric field intensity pattern established within the container.

Nanometer-scale objects likely to be manipulated by the method and system disclosed herein include molecular diodes, molecular transistors, molecular logic devices or other circuits formed by a single molecule, molecular structures which function as "wires", molecules having medical/pharmacological significance, etc. Components of quantum computers, other novel types of nanocomputers, and nanomachines also are likely to be manipulated and assembled by this method.

While there is great interest in development of electronic devices and circuits formed from single molecules, there is also great interest in structures that can serve as interconnecting conductive elements for combining the molecular and other nanometer-scale circuits into more complex functions. One promising conductive element is the carbon nanotube. By adjustment of the location of standing waves of particulates **110'**, objects such as nanotubes can be arranged in a predetermined electrical circuit pattern. In order to make use of that circuit pattern, the nanotubes **130** need to be applied to a substrate, as do molecular circuit elements to be combined into more complex circuits.

Referring to FIG. **7**, one method for applying the objects **130** to a substrate is shown. In this example, the substrate **134** is disposed above the objects **130**, wherein the lower surface of the substrate **134** is adapted for adherence of the objects thereto. Such adaptation may be in the form of selecting a substrate material which has an affinity for the composition of the objects **130**, the application of a coating that provides a bond between the objects **130** and the substrate **134**, or the application of a particular charge to the substrate **134** to attract the objects **130**. The substrate **134** may be positioned in or on container **120** prior to the establishment of the patterned granular motion or subsequent thereto. Once the objects **130** have been positioned on the bottom substrate surface, the substrate may be separated from the container **120** and passed on for further processing,

which may include the separation of the substrate into a plurality of individual segments, not unlike the separation of a wafer due to a plurality of integrated circuit chips. Thus, a plurality of substantially identical and separable nanoscale circuits or circuit patterns can be formed simultaneously.

The space **124** in which the objects are disposed, between the plurality of particulates **110'** and the bottom surface of the substrate **134**, may be filled with a medium, such as a vacuum, a gas, a liquid, or a gel. Such a medium would facilitate processing or take advantage of a particular characteristic of the objects being manipulated, or facilitate the use of a particular material as the particulates.

Referring now to FIG. **8**, there is shown another method by which the objects **130** are positioned and applied to a substrate. In this arrangement, the substrate **134** is positioned between the objects **130** and the particulates **110'**, with the electric fields generated by the standing waves **112** acting on the objects **130** through substrate **134**. The objects **130** can be made to adhere to the substrate **134** by the methods previously discussed, or treated subsequent to positioning of the objects in order to affix them to substrate **134**. The substrate **134** can form a closure for the portion of the container **120** where the particulates **110'** are disposed. Therefore, the space **124** between the particulates **110'** and the substrate **134** may be filled with a selected medium that promotes a desired characteristic, such as utilization of a vacuum to reduce resistance that the molecules of a gas or liquid would introduce. Above the substrate **134** the space **126** may be filled with the same or a different medium. For instance, if the objects **130** are molecular circuits which are formed by bulk processing in a liquid, that liquid may be maintained within the space **126** until the objects **130** are positioned in the desired configuration. The particulates, on the other hand, may be disposed in an evacuated space to reduce resistance to their movement.

Where molecules are being sorted for medical/pharmaceutical applications, the medium within the space **126** is likely to be a gel. As shown in FIG. **9**, the gel **136** is disposed above the substrate **134** with the objects **130a** and **130b** being displaced in different directions as a result of the field formed by the standing wave **112** of particulates **110'**, the particulates **110'** being in a non-gel medium. Such gels already are widely used in electrophoretic processes. The patterned granular motion established in nanometer-scale particulates provides much finer control of the electrophoretic process, and the capability to perform that process in two or three dimensions.

Referring now to FIG. **10**, there is shown an illustration of a carbon nanotube **130c** disposed on the substrate **134**. In addition to positioning the nanotube **130c** at a precise location on the substrate **134**, the standing waves **112** of particulates **110'** can be utilized to distort the nanotube **130c**. The distortion may range from a slight angular offset or translation, where the electrical characteristics of the nanotube are unaffected, to a kink, where the electrical characteristics of the nanotube are changed as a result. Thus, where the standing waves take the form of stripes **112'**, as shown in FIGS. **11A**, **11B** and **11C**, a nanotube **130c** that is charged negatively will align itself with a respective stripe **112'** of opposite charge polarity. Thus, as in FIG. **11C**, where a respective stripe **112'** has an arcuate shape, the nanotube **130c** will likewise be bent into that arcuate contour. Where the radius of the arcuate contour is small, as illustrated in FIG. **11A**, the nanotube **130c** will be bent to the extent of "kinking", wherein the electrical characteristics of the nanotube is affected. In addition to such deformations, the nanotube **130c** can be translated from one position to

another, as shown in FIG. **11B**. Where the standing waves are positioned in more complex patterns, the nanotubes **130c** can likewise be deformed into more complex shapes.

Thus, predetermined topological configurations of patterned granular formations can be selectively formed by the application of oscillating signals having predetermined waveforms to the electric field emission system **145**. Electric fields established by the electric field emission system **145**, in turn, add energy to the charged particulates **110'** disposed in container **120**, the energy being sufficient to establish patterned granular motion in the particulates. The patterned granular motion of charged particulates **110'** consists of respective standing waves, with the standing waves generating electric fields that are used to arrange objects dynamically. Through the use of electric fields to establish patterned granular motion, nanometer-scale particulates, such as C_{60} can be utilized to manipulate nanometer-scale objects. Nanometer-scale objects such as conductors defined by carbon nanotubes or polyphenylene molecular wires, molecules defining molecular electronic devices, quantum computer components, or nanomechanical components, can thereby be manipulated en masse.

For larger, micron and millimeter scale devices, the energy can be added to particulates utilizing vibratory transducers to displace a wall of the container **120** and thereby establish patterned granular motion. The standing waves formed by the patterned granular motion then may be utilized to manipulate objects by virtue of the collision between the particulates in the standing waves and the respective objects. Like the arrangement shown in FIG. **7**, with respect to the placement of a substrate, the objects manipulated by the standing waves generated by the vibratory displacement of a container wall, can be made to adhere to the lower surface of a substrate to provide a plurality of substantially identical patterns thereon.

As previously discussed, predetermined standing wave patterns of particulates are established by specifying predetermined coefficients of one or more Fourier series representing waveforms supplied by the power source **150**. The manipulation of objects may be carried out in discrete steps, with the waveforms of signals from power source **150** being changed over time in accordance with a predetermined program. The manipulation of the objects, however, can be made more precise if the waveforms output from power source **150** are actively modified in response to the manipulation. Such a feedback arrangement is schematically illustrated for system **100''** in FIG. **12**. As discussed previously, the signal source **150** provides signals having waveforms established to provide predetermined standing wave patterns of particulates. The output from power source **150** is coupled to the energy application system **140** for transferring the energy from the power source output to the particulates within container **120**. As discussed previously, the energy application can be either mechanical or electrical.

Additionally, robotic manipulation system **100''** includes a sensing system **160** to provide feedback for adjustment of the one or more waveforms output from power source **150**, to thereby adjust the positions of standing waves within container **120**. While system **100''** manipulates a plurality of objects **130** in parallel, sensing system **160** monitors the position and/or other characteristics of a portion of the objects, as few as one. Based on the sensed position or other measured characteristic, sensing system **160** provides an output to power source **150** to alter the one or more waveforms output thereby. Sensing system **160** may include optical/imaging or scanning probe microscopy equipment to sense position of the objects. Electrical and/or optical sens-

ing may be included to monitor other characteristics of the objects that change as the objects are manipulated. Thus, probes of an atomic force microscope can be used to make contact with a carbon nanotube that is being manipulated, the probes being coupled to electronic monitoring equipment for measuring the electrical conductance, for example, of the nanotube and detect the formation of a “kink” therein. One use of feedback, for example, is to provide more precise manipulation of objects.

The method for robotic manipulation of a plurality of objects includes the steps of providing a container, the container being capable of generating rapid granule rebounds at a high frequency, and providing a plurality of particulates in the container. The objects to be manipulated are added to the container and the particulates are agitated with energy having predetermined waveforms to generate standing wave patterns therewith (i.e., patterned granular motion). The standing wave patterns dynamically arrange the objects, where the arrangements can be predetermined circuit configurations of objects defined by electronic devices or electrical circuit patterns of objects defined by electrically conductive structures, for example. The arrangement of objects may also form other types of assemblies as well. The method also includes the positioning of a substrate in the container, wherein the substrate is adapted for adhesion of the objects thereto. The positioning of the substrate can precede the agitation of the particulates, or be subsequent thereto. The agitation of the plurality of particulates may be achieved by vibrating a wall of the container. Another method of agitating particulates, where the particulates are charged with a predetermined polarity, is to establish an oscillating electric field within the container. The objects to be manipulated have a size less than 10 microns, i.e., a diameter less than 10 microns, or the smallest dimension of the object’s outer contour being less than 10 microns, and the objects may be single molecules.

The particulates may themselves be individual molecules, wherein such molecules have a closed-cage structure, e.g., a buckminsterfullerene molecule. Both the particulates and objects can be provided in a medium independently selected from the group consisting of a vacuum, a gas, a liquid, and a gel. Using this method, a plurality of substantially identical nanoscale structures (e.g., electrical, quantum, or mechanical) can be formed on a substrate. Thus, the fabrication of the plurality of circuits, circuit patterns, systems, machines, or assemblies takes place in parallel, constituting a bulk fabrication process.

Although this invention has been described in connection with specific forms and embodiments thereof, it will be appreciated that various modifications other than those discussed above may be resorted to without departing from the spirit or scope of the invention. For example, equivalent elements may be substituted for those specifically shown and described, certain features may be used independently of other features, and in certain cases, particular locations of elements may be reversed or interposed, all without departing from the spirit or scope of the invention as defined in the appended Claims.

What is being claimed is:

1. A system for robotic manipulation of a plurality of object, comprising:

a container

a plurality of particulates disposed in said container;

a plurality of objects to be manipulated disposed in said container, said plurality of objects being distinct from said plurality of particulates;

means for applying energy to said plurality of particulates to establish patterned granular motion thereof and thereby forming a plurality of repeated vertically directed standing waves, said standing waves of said plurality of particulates respectively imparting displacement forces to said plurality of objects; and;

signal means coupled to said energy application mean for supplying said energy with predetermined waveforms to dynamically position said standing waves at predetermined positions one with respect to another, said predetermined portions of said standing waves dynamically displacing and arranging said objects in a predetermined configuration.

2. The system as recited in claim 1 where said energy application means includes means for vibrating a wall of said container.

3. The system as recited in claim 1 where said energy application means includes means for establishing oscillatory electric fields in said container.

4. The system as recited in claim 1 where each of said plurality of particulates is a single molecule.

5. The system as recited in claim 4 where each said single molecule is a molecule having a closed-cage structure.

6. The system as recited in claim 5 where each said closed-cage structural molecule is a buckminsterfullerene molecule.

7. The system as recited in claim 4 where said energy application means includes means for establishing oscillatory electric fields in said container, said standing waves of molecules respectively generating fields that perform said dynamic displacement and arrangement of said objects in said predetermined configuration.

8. The system as recited in claim 4 where said objects are electrically conductive and said predetermined configuration defines a plurality of substantially identical nanoscale circuit patterns.

9. The system as recited in claim 4 where said objects are individual molecules.

10. The system as recited in claim 4 where said particulates and said objects are each in a medium independently selected from the group consisting of a vacuum, a gas, a liquid, and a gel.

11. The system as recited in claim 4 where said objects are molecular circuit elements and said predetermined configuration defines a plurality of substantially identical nanoscale circuits.

12. The system as recited in claim 4 where said objects are mechanical structures and said predetermined configuration defines a plurality of substantially identical nanoscale machine assemblies.

13. The system as recited in claim 1 where said objects are electrically conductive and said predetermined configuration defines a plurality of substantially identical circuit patterns.

14. The system as recited in claim 1 where said particulates and said objects are each in a medium independently selected from the group consisting of a vacuum, a gas, a liquid, and a gel.

15. The system as recited in claim 1 where said objects are individual molecules.

16. The system as recited in claim 1 where said distinction between said plurality of objects and said plurality of particulates is at least one characteristic selected from the group consisting of structure, composition, size or shape.

17. A system for robotic manipulation of a plurality of objects, comprising:

a container

a plurality of ionized molecules disposed in said container;

11

a plurality of objects to be manipulated disposed in said container, each of said objects being distinct from said plurality of ionized molecules and less than 10 microns in size;

means for applying oscillatory electric fields to said plurality of ionized molecules to establish patterned granular motion thereof and thereby form a plurality of repeating vertically directed standing waves, said standing waves of said plurality of particulates respectively imparting displacement forces to said plurality of objects; and,

signal means coupled to said oscillatory electric fields application means for establishing said oscillatory electric fields with predetermined waveforms to dynamically position said standing waves at predetermined positions one with respect to another, said standing waves of ionized molecules respectively generating fields that dynamically displace and arrange the objects into a predetermined configuration.

18. The system as recited in claim 17 where said objects are electrically conductive and said predetermined configuration defines a plurality of substantially identical nanoscale circuit patterns.

19. The system as recited in claim 18 where said objects are carbon nanotubes.

20. The system as recited in claim 19 where said carbon nanotubes are bent by said standing wave generated fields.

21. The system as recited in claim 19 where said carbon nanotubes are distorted by said standing wave generated fields.

22. The system as recited in claim 19 where said carbon nanotubes are translated by said standing wave generated fields.

23. The system as recited in claim 17 where said ionized molecules and said objects are each in a medium independently selected from the group consisting of a vacuum, a gas, a liquid, and a gel.

24. The system as recited in claim 17 where said objects are molecular circuit elements and said predetermined configuration defines a plurality of substantially identical nanoscale circuits.

12

25. The system as recited in claim 17 where said objects are nanometer-scale mechanical elements and said predetermined configuration defines a plurality of substantially identical nanoscale machine assemblies.

26. The system as recited in claim 17 where said distinction between said plurality of objects and said plurality of particulates is at least one characteristics selected from the group consisting of structure, composition, size or shape.

27. A system for robotic manipulation of a plurality of objects, comprising:

a container;

a plurality of particulates disposed in said container;

a plurality of objects to be manipulated disposed in said container and being distinct from said plurality of particulates;

means for applying energy to said plurality of particulates to establish patterned granular motion thereof and thereby forming a plurality of repeating vertically directed standing waves, said standing waves of said plurality of particulates respectively imparting displacement forces to said plurality of objects;

signal means coupled to said energy application means for supplying said energy with predetermined waveforms to dynamically position said standing waves at predetermined positions one with respect to another, said predetermined positions of said standing waves dynamically displacing and arranging the objects in a predetermined configuration; and,

means for monitoring at least one characteristic of at least one of said plurality of objects being manipulated, said monitoring means having an output coupled to said signal means for providing a feedback signal thereto for altering said predetermined waveforms and thereby adjusting said predetermined configuration.

28. The system as recited in claim 27 where said distinction between said plurality of objects and said plurality of particulates is at least one characteristic selected from the group consisting of structure, composition, size or shape.

* * * * *